

RD500ASV Surfacing and Joining

4-Axes Weaver Automate – short information

Modular system, for all arc welding methods at railway

Maintenance of rails, frogs and crossings

Hard facing of manganese rails

Special start/stop sequences for less tension of material

Automatic Joint Welding of all kind of rails

Effectively material- and time-saving because of minimum joint space of only 12 mm

3D real time calculation and adjustment of constant welding power

Support for your quality management system and documentation

System-Parts:

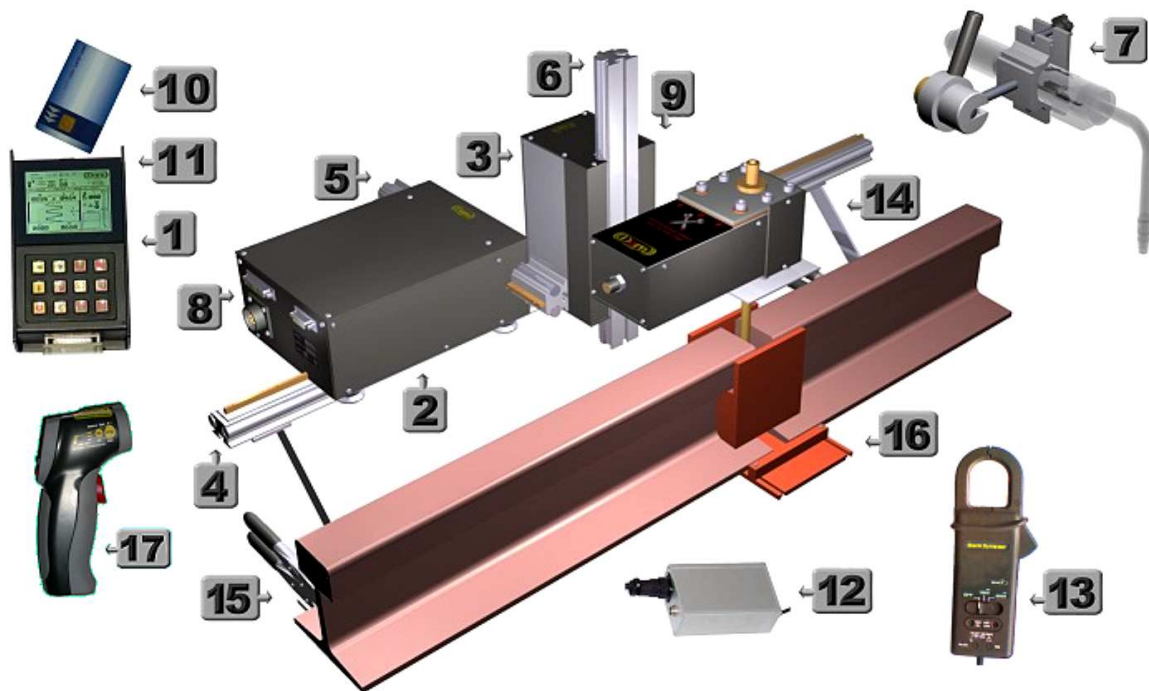

- 1 Remote RD100E (Evolution)
- 2 Drive and Weaver
- 3 Distance Support
- 4 Drive rail, 1500 mm
- 5 Weaver arm, 400 mm
- 6 Distance rail, 300 mm
- 7 Turn able gun-holder
- 8 Mounting knob Drive unit
- 9 Mounting knob Support

- 10 Auto-Start from Chip-Card
- 11 Remote ON/OFF switch
- 12 Power Supply
- 13 Arc Control
- 14 Rotary Support
- 15 Fast fixing Clamps
- 16 Weld protection (Copper)
- 17 Temperature check